



Greenhouse and Energy Minimum Standards (Refrigerated Cabinets) Determination 2018

I, [insert name], Minister for [insert Ministry], make the following determination.

Dated

Exposure draft

November 2018

[insert name] **DRAFT ONLY—NOT FOR SIGNATURE**
Minister for [insert Ministry]

*Greenhouse and Energy Minimum Standards (Refrigerated Cabinets)
Determination 2018*

Exposure draft

November 2018

Contents

Part 1 —Preliminary	2
1 Name	2
2 Commencement, revocation and replacement	2
3 Authority	2
4 Definitions—standards referred to in this determination	2
5 Definitions—other expressions used in this determination	3
6 Meaning of <i>refrigerated cabinet</i>	5
7 Meaning of <i>integral</i> and <i>remote</i>	6
8 Types of refrigerated cabinets	6
9 Meaning of <i>horizontal</i> and <i>vertical</i>	7
10 M-package temperature classes	7
11 Meaning of <i>light duty</i> , <i>normal duty</i> and <i>heavy duty</i>	8
12 Meaning of <i>E24h</i> and <i>energy consumption</i>	9
13 Meaning of <i>low sales volume</i> and <i>oversize</i>	10
14 Interpretation	11
15 Families of models	11
16 Product category	13
17 Registrations affected by this determination	13
Part 2 —Products covered by determination	14
18 Purpose of Part	14
19 Classes of products that are covered by this determination	14
20 Classes of products that are not covered by this determination	14
Part 3 —GEMS level requirements	16
Division 1 —Preliminary	16
21 Purpose of Part	16
22 Definitions	16
Division 2 —GEMS level requirements	16
23 GEMS level requirements	16
24 Calculation of <i>energy efficiency index</i> or <i>EEI</i>	17
25 Calculation of annual energy consumption (<i>AEC</i>) and reference annual energy consumption (<i>RAEC</i>)	17
Division 3 —Conducting tests	20
26 Testing requirements—general	20
27 Additional testing requirements—integral, low sales volume RDC that is not oversize and low sales volume RSCs	20
Part 4 —GEMS labelling requirements	22
28 Purpose of Part	22
29 Use of star ratings	22
30 Impact of replacement determination	22
Part 5 —Other requirements	23
31 Purpose of Part	23
32 Requirement relating to M-package temperature class	23
33 Marking plates	23

Schedule 1 —Product classes	25
1 Product classes	25
Schedule 2 —Registrations affected by this determination	26
1 Registrations affected by this determination	26
Schedule 3 —Variations to standards	27
1 Variations that relate to ISO 23953-2	27
2 Variations that relate to EN 16825	28
3 Variations that relate to EN 16901	29
Schedule 4 —M-package temperature classes	30
1 M-package temperature classes—RDCs, RSCs and scooping cabinets	30
2 M-package temperature classes—ice cream freezer cabinets	30
Schedule 5 —Test room climate classes	31
1 Test room climate classes	31
Schedule 6 —Star ratings	32
1 Star ratings	32

COPYRIGHT

© 2018 Commonwealth of Australia

This determination includes material from European Committee for Standardisation and International Organisation for Standardisation Standards, which is copyright those organisations. Apart from reproduction for personal and non-commercial use, and uses permitted under the *Copyright Act 1968*, European Committee for Standardisation and International Organisation for Standardisation material may not be reproduced without permission or licence.

With the exception of the Commonwealth Coat of Arms, Commonwealth copyright material is licensed under the Creative Commons Attribution-Non-Commercial-ShareAlike 4.0 International Licence. To view a copy of this license, visit <https://creativecommons.org/licenses/by-nc-sa/4.0/>.

You are free to copy, communicate and adapt the Commonwealth copyright material, so long as you attribute the Commonwealth of Australia.

Complete European Committee for Standardisation and International Organisation for Standardisation standards are available for purchase from Standards Australia Ltd. Requests and inquiries concerning other reproduction and rights pertaining to standards should be directed to Standards Australia Ltd.

Part 1—Preliminary

1 Name

This instrument is the *Greenhouse and Energy Minimum Standards (Refrigerated Cabinets) Determination 2018*.

2 Commencement, revocation and replacement

This determination:

- (a) commences and comes into force on the day after the end of the period of 12 months beginning on the day this instrument is registered; and
- (b) revokes the *Greenhouse and Energy Minimum Standards (Refrigerated Display Cabinets) Determination 2012*; and
- (c) replaces that determination.

Note: The form of this section reflects the requirements of sections 34 and 35 of the Act, which deal with how a GEMS determination enters into force and how it replaces an earlier one. Subsection 35(2) of the Act provides that, when a GEMS determination is revoked and replaced, the revoked determination ceases to be in force immediately before the replacement determination comes into force.

3 Authority

This determination is made under sections 23 and 35 of the *Greenhouse and Energy Minimum Standards Act 2012*.

4 Definitions—standards referred to in this determination

Note 1: Subsection 14(2) provides that the applicable version of each standard referred to in this section is the version that existed at the date this determination was made.

Note 2: The standards referred to in this determination can be purchased from Standards Australia Ltd, Standards New Zealand, or the British Standards Institute.

Note 3: The EN and ISO standards referred to in this section specify the following:

- requirements relating to the cabinets they cover;
- test conditions and methods for checking that those requirements have been satisfied;
- classifications of the cabinets;
- markings for the cabinets;
- characteristics of the cabinets to be declared by the manufacturer.

In this determination:

EN 16825 means *European Standard 16825:2016 Refrigerated storage cabinets and counters for professional use — Classification, requirements and test conditions*, as varied in accordance with section 2 of Schedule 3 to this determination.

Note: EN 16825 covers refrigerated cabinets that are designed for the storage of foodstuffs.

EN 16838 means *European Standard 16838:2016 Refrigerated display scooping cabinets for gelato — Classification, Requirements and test conditions*.

Note: EN 16838 covers refrigerated cabinets that are designed for the sale and display of gelato.

EN 16901 means *European Standard 16901:2016 Ice cream freezers — Classification, requirements and test conditions*, as varied in accordance with section 3 of Schedule 3 to this determination.

Note: EN 16901 covers refrigerated cabinets that are designed specifically for the storage and display of pre-packed ice cream.

IEC 60335 means *Australian/New Zealand Standard 60335.2.89:2010, Household and similar appliances – Safety. Part 2.89: Particular requirements for commercial refrigerating appliances with an incorporated or remote refrigerant condensing unit or compressor*.

Note: IEC 60335 incorporates amendments No. 1 and No. 2.

ISO 23953-1 means *International Organisation for Standardisation Standard 23953-1:2015, Refrigerated display cabinets – Part 1: Vocabulary*.

ISO 23953-2 means *International Organisation for Standardisation Standard 23953-2:2015, Refrigerated display cabinets – Part 2: Classification, requirements and test conditions*:

- (a) as varied in accordance with subsection 1(1) of Schedule 3; and
- (b) in relation to determining the energy consumption (*E24h*) or energy efficiency index (*EEI*) of a low sales volume RSC—as further varied in accordance with subsection 1(2) of Schedule 3.

Note: ISO 23953-2 covers refrigerated cabinets that are designed for the display of foodstuffs. Under this determination, ISO 23953-2 is also used to calculate the energy consumption (*E24h*) and energy efficiency index (*EEI*) of low sales volume RSCs.

5 Definitions—other expressions used in this determination

In this determination:

Act means the *Greenhouse and Energy Minimum Standards Act 2012*.

E24h or **energy consumption**—see section 12.

EEI: see *energy efficiency index*.

energy consumption: see *E24h*.

energy efficiency index, or **EEI**, of a refrigerated cabinet means the amount calculated for the cabinet in accordance with section 24.

heavy duty, in relation to an RSC—see section 11.

horizontal, in relation to an RDC or an RSC—see section 9.

ice cream freezer cabinet—see section 8.

icemaker—see subsection 20(2).

integral—see section 7.

light duty, in relation to an RSC—see section 11.

low-efficiency reference set—see subsection 22(1).

low sales volume, in relation to an RDC or an RSC—see section 13.

M-package temperature class—see subsection 10(1).

meets the requirements of an M-package temperature class—see subsection 10(2).

net volume, or V_N , of an ice cream freezer cabinet or an RSC, means the net volume of the cabinet in litres, and is determined in accordance with:

- (a) for an ice cream freezer cabinet—Annex B of EN 16901; and
- (b) for an RSC—clause 6.1 of EN 16825.

Note 1: Section 2 of Schedule 3 to this determination sets out variations to EN 16825 that apply for the purposes of this determination.

Note 2: Section 3 of Schedule 3 to this determination sets out variations to EN 16901 that apply for the purposes of this determination.

Note 3: For the purposes of this determination, the net volume of an RDC or a scooping cabinet do not need to be determined.

normal duty, in relation to an RSC—see section 11.

oversize, in relation to an RDC—see section 13.

parent model, in relation to a family of models—see subsection 15(2).

product class—see section 19.

RDC (short for refrigerated display cabinet)—see section 8.

reference low-efficiency version—see subsection 22(1).

refrigerated cabinet—see section 6.

refrigerated drinks cabinet—see section 8.

refrigerated vending machine—see subsection 20(2).

relevant component—see subsection 22(1).

remote—see section 7.

RSC (short for refrigerated storage cabinet)—see section 8.

scooping cabinet—see section 8.

specific energy consumption—see subsection 15(9).

TDA, or **total display area**, of an RDC or a scooping cabinet, means the total display area of the cabinet in square metres, and is determined in accordance with:

- (a) for an RDC—Annex A of ISO 23953-2; and
- (b) for a scooping cabinet—clause 6.2 of EN 16838.

Note 1: Section 1 of Schedule 3 to this determination sets out variations to ISO 23953-2 that apply for the purposes of this determination.

Note 2: For the purposes of this determination, the total display area (if any) of an ice cream freezer cabinet or an RSC do not need to be determined.

test room climate class means a test room climate class set out in Schedule 5.

test standard means:

- (a) for an RDC—ISO 23953-1 and ISO 23953-2; and
- (b) for an RSC:
 - (i) when determining the energy consumption (*E24h*) or energy efficiency index (*EEL*) of a low sales volume RSC—ISO 23953-2; and
 - (ii) for any other purpose—EN 16825; and
- (c) for an ice cream freezer cabinet—EN 16901; and
- (d) for a scooping cabinet—EN 16838.

Note 1: Section 1 of Schedule 3 to this determination:

- sets out variations to ISO 23953-2 that apply for the purposes of this determination; and
- provides for how ISO 23953-2 applies in relation to low sales volume RSCs.

Note 2: Section 2 of Schedule 3 to this determination sets out variations to EN 16825 that apply for the purposes of this determination.

Note 3: Section 3 of Schedule 3 to this determination sets out variations to EN 16901 that apply for the purposes of this determination.

total display area: see *TDA*.

vertical, in relation to RDCs and RSCs—see section 9.

V_N : see *net volume*.

water cooled condenser—see subsection 20(2).

Note: Several other words and expressions used in this determination have the meaning given by section 5 of the Act. For example:

- category A product;
- covered by;
- family of models;
- GEMS;
- GEMS labelling requirements;
- GEMS level requirements;
- GEMS Regulator;
- model;
- product classes.

6 Meaning of *refrigerated cabinet*

In this determination:

refrigerated cabinet means a device that:

- (a) consists of an insulated cabinet with an opening (whether or not the opening has a lid or a door); and
- (b) is capable of attaining and maintaining a specified temperature within the insulated cabinet within a range that overlaps the range -18°C to $+10^{\circ}\text{C}$; and
- (c) is designed primarily for storage, display, or both storage and display, of chilled or frozen foodstuffs.

Note: For the purposes of this determination, there are 5 types of refrigerated cabinet—see section 8.

7 Meaning of *integral* and *remote*

In this determination:

integral: a refrigerated cabinet is ***integral*** if it is designed to have its condensing unit housed within, or directly attached to, the cabinet.

remote: a refrigerated cabinet is ***remote*** if it is not integral.

8 Types of refrigerated cabinets

In this determination:

ice cream freezer cabinet means a refrigerated cabinet that:

- (a) is designed for storage and display of, and access by consumers to, pre-packaged frozen ice cream; and
- (b) is integral; and
- (c) can be accessed by opening a lid (whether solid or transparent); and
- (d) has a net volume, when determined in accordance with Annex B of EN 16901 as if the cabinet were covered by that standard, of no more than 500 litres; and
- (e) has a ratio of its net volume (V_N) to total display area (TDA) of greater than or equal to 0.35 m; and
- (f) has static air cooling with a skin evaporator.

Note 1: For the purposes of this determination, definitions and requirements relating to ice cream freezer cabinets are found in EN 16901.

Note 2: Section 3 of Schedule 3 to this determination sets out variations to EN 16901 that apply for the purposes of this determination.

RDC (short for refrigerated display cabinet) means a refrigerated cabinet that:

- (a) is designed for storage and display of, and access by consumers to, chilled or frozen items contained in the cabinet in a retail environment; and
- (b) is not:
 - (i) a scooping cabinet; or
 - (ii) an ice cream freezer cabinet.

Note 1: For the purposes of this determination, RDCs may be designed:

- to be open, or to have transparent doors, drawers or lids; and
- to be integral or remote.

Note 2: For the purposes of this determination, definitions relating to RDCs are found in ISO 23953-1 and requirements relating to RDCs are found in ISO 23953-2.

Note 3: Section 1 of Schedule 3 to this determination sets out variations to ISO 23953-2 that apply for the purposes of this determination.

Note 4: A refrigerated cabinet will be an RDC if it meets this definition, regardless of the environment (for example, industrial commercial or domestic) in which it is actually used.

refrigerated drinks cabinet means an RDC that:

- (a) is designed for non-perishable drinks only; and
- (b) is integral.

RSC (short for refrigerated storage cabinet) means a refrigerated cabinet that:

- (a) is integral; and
- (b) is not:
 - (i) an RDC; or
 - (ii) a scooping cabinet; or
 - (iii) an ice cream freezer cabinet.

Note 1: For the purposes of this determination, refrigerated storage cabinets may be designed:

- to have transparent, partially transparent, or opaque doors, drawers or lids; and
- to contain chilled or frozen items.

Note 2: This determination does not apply to RSCs that are designed to be remote.

Note 3: For the purposes of this determination, definitions and requirements relating to RSCs are generally found in EN 16825. For low sales volume RSCs, ISO 23953-2 is used to calculate the energy consumption (*E24h*) and energy efficiency index (*EEI*).

Note 4: Section 2 of Schedule 3 to this determination sets out variations to EN 16825 that apply for the purposes of this determination.

Note 5: A refrigerated cabinet will be an RSC if it meets this definition, regardless of the environment (for example, industrial commercial or domestic) in which it is actually used.

scooping cabinet means a refrigerated cabinet that:

- (a) is designed for the storage, display and scooping of containerised frozen gelato or ice cream; and
- (b) is integral.

Note: For the purposes of this determination, requirements relating to scooping cabinets are found in EN 16838.

9 Meaning of *horizontal* and *vertical*

- (1) An RDC is:
 - (a) **horizontal** if it has an access opening only in its uppermost horizontal surface (whether or not the access opening can be closed by a door or a lid); and
 - (b) **vertical** otherwise.
- (2) An RSC is:
 - (a) **horizontal** if it has an overall height, when determined in accordance with EN 16825, of no greater than 1,050 mm; and
 - (b) **vertical** otherwise.

Note: Section 2 of Schedule 3 to this determination sets out variations to EN 16825 that apply for the purposes of this determination.

10 M-package temperature classes

Note 1: An M-package temperature class is a classification of refrigerated cabinets according to the temperatures of the warmest and coldest test packages (known as “M-packages”) recorded during the temperature test as defined in the relevant test standard.

Note 2: See section 32 for requirements relating to the M-package temperature class.

- (1) In this determination:

M-package temperature class means a temperature class that is set out in:

- (a) for an RDC, an RSC or a scooping cabinet—section 1 of Schedule 4 to this determination; and
 - (b) for an ice cream freezer cabinet—section 2 of Schedule 4 to this determination.
- (2) For this determination, a particular refrigerated cabinet **meets the requirements** of a particular M-package temperature class if, when the cabinet is tested:
- (a) in accordance with the relevant test standard; and
 - (b) at a particular test room climate class;
- the requirements that are specified, in Schedule 4 to this determination, for that M-package temperature class and for that type of cabinet are satisfied.

11 Meaning of *light duty*, *normal duty* and *heavy duty*

Note 1: For the purposes of this determination, only RSCs are classified as light duty, normal duty or heavy duty.

Note 2: Under section 23, the GEMS level requirements for heavy duty RSCs differ from those of light or normal duty RSCs.

- (1) In this determination:

heavy duty: an RSC is **heavy duty** if, when tested:

- (a) in accordance with clause 5.3.4 of EN 16825; and
- (b) in ambient conditions corresponding to test room climate class 5;

it is capable of continuously meeting the requirements for the relevant M-package temperature class in all of its compartments.

Note: Section 2 of Schedule 3 to this determination sets out variations to EN 16825 that apply for the purposes of this determination.

light duty: an RSC is **light duty** if:

- (a) it is not heavy duty or normal duty; and
- (b) when tested:
 - (i) in accordance with clause 5.3.4 of EN 16825; and
 - (ii) in ambient conditions corresponding to test room climate class 3;

it is capable of continuously meeting the requirements for the relevant M-package temperature class in all of its compartments.

Note: Section 2 of Schedule 3 to this determination sets out variations to EN 16825 that apply for the purposes of this determination.

normal duty: an RSC is **normal duty** if:

- (a) it is not heavy duty; and
- (b) when tested:
 - (i) in accordance with clause 5.3.4 of EN 16825; and
 - (ii) in ambient conditions corresponding to test room climate class 4;

it is capable of continuously meeting the requirements for the relevant M-package temperature class in all of its compartments.

Note: Section 2 of Schedule 3 to this determination sets out variations to EN 16825 that apply for the purposes of this determination.

Meaning of relevant M-package temperature class

- (2) For this section, the **relevant M-package temperature class** is:
- for an RSC that is designed for storage of chilled foodstuffs—M1; and
 - for an RSC that is designed for storage of frozen foodstuffs—L1.

12 Meaning of E24h and energy consumption

- (1) In this determination:

energy consumption or **E24h**, in relation to a refrigerated cabinet, means the energy consumption of the cabinet over a 24 hour period, in kWh per 24 hours, and is equal to the amount determined in accordance with subsection (2).

- (2) For subsection (1), the table has effect:

Item	For:	the energy consumption, or E24h, is equal to the amount:	as determined in accordance with:	at test room climate class:
1	an RDC	<i>TEC</i>	clauses 5 and 6 of ISO 23953-2	3
2	an ice cream freezer cabinet	<i>TEC</i>	clauses 6 and 7 of EN 16901	4
3	a scooping cabinet	<i>TEC</i>	clauses 6 and 7 of EN 16838	4
4	a light duty RSC, other than one covered by item 5	<i>E24h</i>	clauses 5, 6 and 7 of EN 16825	3
5	an RSC that is: (a) light duty; and (b) low sales volume	<i>TEC</i>	clauses D.4.2 and D.4.3 of ISO 23953-2	3
6	a normal duty or heavy duty RSC, other than one covered by item 7	<i>E24h</i>	clauses 5, 6 and 7 of EN 16825	4
7	an RSC that is: (a) normal duty or heavy duty; and (b) low sales volume	<i>TEC</i>	clauses D.4.2 and D.4.3 of ISO 23953-2	4

Note 1: Section 1 of Schedule 3 to this determination:

- sets out variations to ISO 23953-2 that apply for the purposes of this determination; and
- provides for how ISO 23953-2 applies in relation to low sales volume RSCs.

Note 2: Section 2 of Schedule 3 to this determination sets out variations to EN 16825 that apply for the purposes of this determination.

Note 3: Section 3 of Schedule 3 to this determination sets out variations to EN 16901 that apply for the purposes of this determination.

Note 4: For items 5 and 7 of the table, the main formula for calculating the *TEC* is formula D.14 of Annex D to ISO 23953-2, which is set out in clause D.4.2 of that Annex. This formula relies on formulae D.4, D.5, D.6, D.7, D.8 and D.15 of Annex D.

13 Meaning of *low sales volume* and *oversize*

Note 1: For the purposes of this determination:

- models of ice cream freezer cabinets and scooping cabinets cannot be “low sales volume”; and
- models of ice cream freezer cabinets, scooping cabinets and RSCs cannot be “oversize”.

Note 2: A model of an RDC could be “low sales volume”, “oversize”, both, or neither. A model of an RSC might or might not be “low sales volume”.

Note 3: Under this determination, the annual energy consumption (*AEC*) and reference annual energy consumption (*RAEC*), and hence the energy efficiency index (*EET*), of “low sales volume” and/or “oversize” RDCs, and of “low sales volume” RSCs, are calculated differently from other RDCs and RSCs (see sections 24 and 25). There is also an additional testing requirement for some “low sales volume” RDCs and RSCs (see section 27).

Note 4: For “low sales volume” RDCs and RSCs, the GEMS Regulator may request evidence of annual sales volumes under section 56 of the Act.

Note 5: A model of an RDC or an RSC may be registered on the basis that it is “low sales volume”. For such a model, annual sales must not exceed the threshold sales volumes specified in this section in order for the model to continue to be classified as “low sales volume”.

For an RDC, if at some time after registration, its annual sales exceed the threshold sales volumes, unless models of the product are also “oversize”, they will need to comply with the requirements of this determination that apply to RDCs generally.

For an RSC, if at some time after registration, its annual sales exceed the threshold sales volumes, models of the product will need to comply with the requirements of this determination that apply to RSCs generally.

If the models do not satisfy these general requirements, the GEMS Regulator might consider suspending or cancelling the model’s registration under Division 6 of Part 5 of the Act, or might consider commencing enforcement action.

In this determination:

low sales volume: an RDC or an RSC is ***low sales volume*** at a particular date:

- (a) for an RDC or an RSC of a model that belongs to a family of models—if:
 - (i) the family of models is registered as a low sales volume family of models; and
 - (ii) no more than 25 units of the models that belong to the family of models are sold in the calendar year that includes that date; or
- (b) for an RDC or an RSC of a model that that does not belong to a family of models—if:
 - (i) the model is registered as a low sales volume model; and
 - (ii) no more than 10 units of the model are sold in the calendar year that includes that date.

oversize: an RDC is ***oversize*** if, at the time of:

- (a) if the model of the product was registered as a result of an application under section 41 of the Act—that application; or
- (b) if the model of the product was registered as a result of a subsequent application under section 46 of the Act—that application;

as a result of its size, there is no testing laboratory:

- (c) in which the RDC is able to be tested in accordance with ISO 23953-2; and
- (d) that has been approved by the National Association of Testing Authorities, Australia.

Note: Section 1 of Schedule 3 to this determination:

- sets out variations to ISO 23953-2 that apply for the purposes of this determination; and
- provides for how ISO 23953-2 applies in relation to low sales volume RSCs.

14 Interpretation

Applicable definitions of terms or phrases

- (1) If there is inconsistency in the definitions of words or expressions, words or expressions will be interpreted in the following order of priority to the extent of any inconsistency:
 - (a) the Act;
 - (b) this determination;
 - (c) a standard referred to in this determination, or another standard referred to in such a standard.

Applicable version of standards or documents incorporated into standards

- (2) For the purposes of this determination, the applicable version of any:
 - (a) standard; or
 - (b) other document that:
 - (i) is referred to in a standard under the heading “Normative References” or under an equivalent heading; and
 - (ii) must be applied to give effect to this determination or a standard referred to in this determination;

is the version of the standard or other document that existed at the date this determination was made.

Meaning of terms that are used in a relevant test standard

- (3) Unless the contrary intention appears, an expression used in this determination has the same meaning as in the relevant test standard.

15 Families of models

- (1) For section 28 of the Act, for a particular product class covered by this determination, two or more models are in the same family of models if:
 - (a) they are members of a family that has been declared to the GEMS Regulator; and
 - (b) the requirements of this section are satisfied in relation to the models and the family.

Parent model requirements

- (2) There must be a single model (the *parent model*) for each family that:
 - (a) when compared to the other models in the family:
 - (i) has the highest, or the equal highest, specific energy consumption (see subsection (9)); and
 - (ii) meets the requirements of the coldest, or the equal coldest, M-package temperature class when tested in accordance with the relevant test standard; and
 - (iii) has the largest, or the equal largest, vertical or horizontal opening; and
 - (iv) has the greatest, or the equal greatest, horizontal distance between the front and the rear of the cabinet; and

- (b) is included on a test report that was prepared prior to the application for registration being made under section 41 of the Act for any model that is a member of the family.

Family model requirements

- (3) Each model in the family must:
 - (a) be in the same product class as the parent model; and
 - (b) meet the requirements of:
 - (i) the same M-package temperature class as the parent model; or
 - (ii) a warmer M-package temperature class than the parent model.

Additional requirements if parent model is an RDC

- (4) If the parent model is an RDC, each model in the family must have:
 - (a) the same characteristics as the parent model in relation to:
 - (i) whether it is open or closed; and
 - (ii) whether it is oversize; and
 - (b) unless paragraph (c) provides otherwise—a total display area that is the same as that of the parent model; and
 - (c) if the family consists of models:
 - (i) that are remote; and
 - (ii) that are of modular construction; and
 - (iii) some or all of which are of different lengths;the same ratio of cabinet length to total display area as that of the parent model.

Additional requirements if parent model is an RSC

- (5) If the parent model is an RSC, each model in the family must have:
 - (a) the same net volume; and
 - (b) the same duty classification (light duty, normal duty or heavy duty);as the parent model.

Additional requirements if parent model is an ice cream freezer cabinet

- (6) If the parent model is an ice cream freezer cabinet, each model in the family must have:
 - (a) the same net volume; and
 - (b) the same total display area;as the parent model.

Additional requirements if parent model is a scooping cabinet

- (7) If the parent model is a scooping cabinet, each model in the family must have the same total display area as the parent model.

Number of models in family

- (8) A family must not contain more than 25 models.

Specific energy consumption

- (9) For subparagraph (2)(a)(i), the **specific energy consumption** of a refrigerated cabinet is equal to:
- (a) for an RDC—the amount *SEC* in kWh per 24 hours per m² as calculated in accordance with clause 5.3.6.3.5 of ISO 23953-2; and
 - (b) for an RSC—the amount *SEC* in kWh per 24 hours per m³ as calculated in accordance with subsection (10); and
 - (c) for a scooping cabinet—the amount *SEC* in kWh per 24 hours per m² as calculated in accordance with clause 6.3.7.3.5 of EN 16838; and
 - (d) for an ice cream freezer cabinet—the amount *SEC* in kWh per 24 hours per m³ as calculated in accordance with clause 6.3.6.6.4 of EN 16901.

Note 1: For paragraph (a), section 1 of Schedule 3 to this determination sets out variations to ISO 23953-2 that apply for the purposes of this determination.

Note 2: For paragraph (d), section 3 of Schedule 3 to this determination sets out variations to EN 16901 that apply for the purposes of this determination. Unlike RSCs, under EN 16901, the amount *SEC* for an ice cream freezer cabinet is calculated by dividing the energy consumption by the “equivalent volume” (rather than the net volume). The “equivalent volume” of an ice cream freezer cabinet is related to the cabinet’s net volume, but is normalised by factors that depend on the M-package temperature class and test room climate class.

- (10) For paragraph (9)(b), for an RSC, the amount *SEC* is given by the following formula:

$$SEC = \frac{\text{energy consumption}}{\text{net volume}}$$

where:

energy consumption is the cabinet’s energy consumption in kWh per 24 hours (see section 12).

net volume is the cabinet’s net volume in cubic metres (see section 5).

16 Product category

For section 29 of the Act, the products covered by this determination are category A products.

17 Registrations affected by this determination

For section 36 of the Act, this determination affects the registration of the models registered against the *Greenhouse and Energy Minimum Standards (Refrigerated Display Cabinets) Determination 2012* that are specified in Schedule 2.

Note 1: If a model’s registration is affected, the model’s registration against the *Greenhouse and Energy Minimum Standards (Refrigerated Display Cabinets) Determination 2012* ceases to be in force. See section 48 of the Act.

Note 2: If a model’s registration is not affected, the model is taken to be registered against this determination. See section 36 of the Act.

Part 2—Products covered by determination

18 Purpose of Part

For subsections 23(1) and (2) of the Act, this Part specifies:

- (a) one or more classes of products that are covered by this determination; and
- (b) one or more classes of products that are not covered by this determination.

19 Classes of products that are covered by this determination

A numbered *product class* set out in Schedule 1 is a class of products covered by this determination.

Note 1: The product classes are numbered 1 to 15.

Note 2: Broadly speaking, the product classes cover the following:

- RDCs;
- refrigerated drinks cabinets;
- ice cream freezer cabinets;
- scooping cabinets;
- RSCs.

Note 3: This determination covers products that fall within the product classes irrespective of the context in which they are used. For example, this determination covers such products regardless of whether they are used in an industrial, commercial or domestic context.

20 Classes of products that are not covered by this determination

(1) This determination does not cover the following:

- (a) refrigerated vending machines;
- (b) icemakers;
- (c) cabinets that are designed for both food processing and storage, whether or not the cabinet includes an integral refrigerated storage section;

Example: For paragraph (c), examples include the following:

- bakery cabinets that chill, heat and humidify;
- open top tables and saladettes for food preparation;
- cabinets specifically intended for storage of foodstuffs (for example, fresh meat, fresh fish) that are designed to operate at temperatures different to those specified in section 1 of Schedule 4 to this determination.

- (d) refrigerated cabinets that have water cooled condensers;
- (e) products covered by the *Greenhouse and Energy Minimum Standards (Household Refrigerating Appliances) Determination 2012*;
- (f) any of the following, within the meaning of EN 16825:
 - (i) built-in cabinets (that is, refrigerated cabinets that are designed to be installed into a prepared recess in a wall or similar location and that require furniture finishing);
 - (ii) roll-in cabinets (that is, refrigerated cabinets that are designed to be loaded with trolleys with shelves which are designed to be introduced into the cabinet as such);

- (iii) pass through cabinets (that is, refrigerated cabinets that are designed to be accessible from both sides);

Note: Section 2 of Schedule 3 to this determination sets out variations to EN 16825 that apply for the purposes of this determination.

- (g) appliances that are intended for short-time or intermittent normal operation during the full day;

- (h) RDCs that:

- (i) are low sales volume, oversize or both; and

- (ii) have an indirect refrigeration system within the meaning of ISO 23953-2 (that is, refrigerated cabinets in which a secondary refrigerant circulating system is installed between a central refrigerating system and the cabinet);

Note: Section 1 of Schedule 3 to this determination sets out variations to ISO 23953-2 that apply for the purposes of this determination.

- (i) RSCs that are not light duty, normal duty or heavy duty.

- (2) In this section:

icemaker means a factory-made commercial assembly that has:

- (a) a condensing unit and ice making section that operate as an integrated unit; and
- (b) means for making and harvesting ice;

whether or not the assembly also includes means for storing ice, dispensing ice, or both.

refrigerated vending machine means a self-contained refrigerated cabinet that is designed to accept consumer payments or tokens to dispense pre-packed beverages or foodstuffs (for example, in the form of cans, bottles or food packets), and that stores products at between 0°C and +5°C.

water cooled condenser means a condenser that uses water as the cooling medium to condense hot refrigeration gas to liquid.

Part 3—GEMS level requirements

Division 1—Preliminary

21 Purpose of Part

This Part specifies:

- (a) GEMS level requirements in accordance with section 25 of the Act for the product classes covered by this determination, for paragraph 24(1)(a) of the Act; and
- (b) testing requirements for the purposes of this Part, for paragraph 25(b) of the Act.

22 Definitions

- (1) In this Part:

low-efficiency reference set: see *reference low-efficiency version*.

reference low-efficiency version of an RDC or an RSC means a hypothetical version of the cabinet in which the set of relevant components is replaced by a set of components (the *low-efficiency reference set*):

- (a) each of which is of a kind listed in column 2 of the table to subsection (2); and
- (b) that collectively perform the same function as the components that are replaced.

Note: For a particular RDC or RSC, there might be more than one possible *reference low-efficiency version* (each having a different *low-efficiency reference set* of components). If there is more than one possible version, any version (having any suitable low-efficiency reference set of components) may be used for the purposes of this Part.

relevant component of a particular RDC or RSC means any component of the cabinet that is of a kind listed in column 1 of the table to subsection (2).

Note: A particular RDC or RSC will have only a single set of *relevant components*.

- (2) For subsection (1), the table is:

	Column 1 Kinds of relevant components	Column 2 Kinds of low-efficiency reference components
1	Fan motor	A shaded pole fan motor with an efficiency of 35% or lower
2	Lighting	Fluorescent lamps with B2 ballasts
3	Anti-condensation heaters	An uncontrolled anti-condensation heater
4	Pan heaters	An uncontrolled pan heater
5	Defrost heaters	A defrost heater that is controlled by a timer

Division 2—GEMS level requirements

23 GEMS level requirements

The table has effect:

Item	For:	the <i>EEI</i> must be:
1	any of the following: (a) an RDC; (b) a scooping cabinet; (c) an ice cream freezer cabinet	< 130
2	a heavy duty RSC	< 115
3	light duty or normal duty RSC	< 95

Note 1: For item 1 of the table, the product class could be any of product classes 1, 2, 5 to 8 or 11 to 15.

Note 2: For items 2 and 3 of the table, the product class could be any of product classes 3, 4, 9 or 10.

Note 3: For the product classes, see section 19 and Schedule 1.

24 Calculation of energy efficiency index or *EEI*

The *energy efficiency index, EEI*, of a refrigerated cabinet that is covered by this determination is calculated in accordance with the following formula:

$$EEI = \frac{AEC}{RAEC} \times 100$$

where:

AEC is the refrigerated cabinet's annual energy consumption, in kWh per year, and is calculated in accordance with section 25.

RAEC is the refrigerated cabinet's reference annual energy consumption, in kWh per year, and is calculated in accordance with section 25.

Note: For refrigerated cabinets that are covered by this determination, other than low sales volume and/or oversize RDCs and low sales volume RSCs, the reference annual energy consumption is equal to the standard annual energy consumption, which represents the energy consumption of a standard cabinet of the relevant type.

For low sales volume and/or oversize RDCs and low sales volume RSCs, the reference annual energy consumption is equal to the base annual energy consumption, which reflects the energy consumption of a reference low-efficiency version of a cabinet of the relevant type.

25 Calculation of annual energy consumption (*AEC*) and reference annual energy consumption (*RAEC*)

Note 1: Most calculations for the purposes of this section rely on calculation of the amount *E24h* (see section 12).

Note 2: For RDCs that are low sales volume and/or oversize, and for RSCs that are low sales volume, the calculations involve determination of various amounts on the basis of:

- the RDC or RSC with the actual components (the relevant components); and
- a hypothetical reference low-efficiency version of the cabinet with a low-efficiency reference set of components.

Note 3: In the case of low sales volume and/or oversize RDCs that are remote, the amounts are:

- the *DEC* (short for direct electrical energy consumption), which is a measure of the energy consumption of the electrical components of the RDC, and which excludes the energy consumption of the remote refrigeration system that runs the RDC (the *REC*); and
- the *REC* (short for refrigeration electrical energy consumption), which is a measure of the energy consumption of the refrigeration system that runs the RDC.

The sum of the *DEC* and the *REC* is a measure of the total energy consumption (the *TEC*) of the RDC.

Note 4: In the case of low sales volume and/or oversize RDCs that are integral, or low sales volume RSCs (which, in order to be covered by this determination, must be integral), only the amount *TEC* is determined (and not the separate amounts *DEC* and *REC*), and this amount is the total energy consumption of the RDC or RSC, including the integral refrigeration system.

(1) For the definitions of *AEC* and *RAEC* in section 24, the table has effect:

Item	For:	<i>AEC</i> is given by	<i>RAEC</i> is given by
1	an RDC, other than one covered by item 5 or item 6	$E24h \times 365$	$(M + (N \times TDA)) \times 365$
2	a scooping cabinet	$E24h \times 365$	$(M + (N \times TDA)) \times 365$
3	an ice cream freezer cabinet	$E24h \times 365$	$(M + (N \times V_N)) \times 365$
4	an RSC, other than one covered by item 7	$E24h \times af \times 365$	$(M \times V_N) + (N \times 365)$
5	an RDC that is: (a) remote; and (b) either or both of the following: (i) low sales volume; (ii) oversize	$(DEC_{actual} + REC_{actual}) \times af \times 365$	$(DEC_{reference} + REC_{actual}) \times 365$
6	an RDC that is: (a) integral; and (b) either or both of the following: (i) low sales volume; (ii) oversize	$TEC_{actual} \times af \times 365$	$TEC_{reference} \times 365$
7	a low sales volume RSC	$TEC_{actual} \times af \times 365$	$TEC_{reference} \times 365$

Definitions—items 1 to 4 (RDCs, scooping cabinets, ice cream freezer cabinets and RSCs)

(2) For items 1 to 4 of the table to subsection (1):

af is the adjustment factor for item 4, and is equal to:

- (a) for a light duty RSC that is a chiller—1.2; and
- (b) for a light duty RSC that is a freezer—1.1; and
- (c) for a normal duty or heavy duty RSC—1.

E24h is the energy consumption of the cabinet in kWh per 24 hours (see section 12).

M is the coefficient for the cabinet's product class, as given by Schedule 1.

N is the coefficient for the cabinet's product class, as given by Schedule 1.

TDA is the total display area of the cabinet, in square metres (see section 5).

V_N is the net volume of the cabinet in litres (see section 5).

Definitions—item 5 (low sales volume or oversize RDCs that are remote)

(3) For item 5 of the table to subsection (1):

af is the adjustment factor for item 5, and is equal to 1.1304.

DEC_{actual} is the electrical energy consumption of the cabinet, as calculated in accordance with Formula D.3 of Annex D to ISO 23953-2 on the basis of amounts for the relevant components of the cabinet that are:

- (a) if the cabinet is low sales volume but not oversize:
 - (i) measured in accordance with Part D.3 of Annex D to ISO 23953-2 (the *relevant provisions*); or
 - (ii) if, for a particular component, measurement is not reasonably practicable—calculated in accordance with the relevant provisions; and
- (b) if the cabinet is oversize (whether or not it is also low sales volume)—calculated in accordance with the relevant provisions.

Note: Section 1 of Schedule 3 to this determination sets out variations to ISO 23953-2 that apply for the purposes of this determination.

DEC_{reference} is the hypothetical electrical energy consumption of a reference low-efficiency version of the cabinet, as calculated in accordance clause D.3.4.1 of Annex D to ISO 23953-2 on the basis of amounts, for the components in the low-efficiency reference set, that are calculated in accordance with Part D.3 of Annex D to ISO 23953-2.

Note: Section 1 of Schedule 3 to this determination sets out variations to ISO 23953-2 that apply for the purposes of this determination.

REC_{actual} is the electrical energy consumption of a refrigeration system that can be used to operate the refrigerated cabinet, and is equal to the amount *REC_{RC}* as determined in accordance with Formula 9 of ISO 23953-2.

Note: Section 1 of Schedule 3 to this determination sets out variations to ISO 23953-2 that apply for the purposes of this determination.

Definitions—items 6 and 7 (low sales volume or oversize RDCs that are integral, low sales volume RSCs)

- (4) For items 6 and 7 of the table to subsection (1):

af is the adjustment factor for items 6 and 7, and is equal to:

- (a) for item 6—1.1304; and
- (b) for item 7:
 - (i) for a heavy duty RSC—1.15; and
 - (ii) for a light duty or normal duty RSC—1.1875.

TEC_{actual} is the total daily electrical energy consumption of the cabinet (including the condensing unit energy consumption), as calculated in accordance with Formula D.14 of Annex D to ISO 23953-2 on the basis of amounts for the relevant components of the cabinet that are:

- (a) for an RDC:
 - (i) if the cabinet is low sales volume but not oversize:
 - (A) measured in accordance with clauses D.4.2 and D.4.3 of Annex D to ISO 23953-2 (the *relevant provisions*); or

- (B) if, for a particular component, measurement is not reasonably practicable—calculated in accordance with the relevant provisions; and
- (ii) if the cabinet is oversized (whether or not it is also low sales volume)—calculated in accordance with the relevant provisions; and
- (b) for an RSC:
- (i) measured in accordance with the relevant provisions; or
- (ii) if, for a particular component, measurement is not reasonably practicable—calculated in accordance with the relevant provisions.

Note 1: Section 1 of Schedule 3 to this determination:

- sets out variations to ISO 23953-2 that apply for the purposes of this determination; and
- provides for how ISO 23953-2 applies in relation to low sales volume RSCs.

Note 2: For the *relevant provisions*, the main formula for calculating the *TEC* is formula D.14 of Annex D to ISO 23953-2, which is set out in clause D.4.2 of that Annex. This formula relies on formulae D.4, D.5, D.6, D.7, D.8 and D.15 of Annex D.

TEC_{reference} is the hypothetical total daily electrical energy consumption of a reference low-efficiency version of the cabinet, as calculated in accordance with clauses D.4.2 and D.4.3 of Annex D to ISO 23953-2 on the basis of:

- (a) in relation to the condensing unit—the value of *CEC*, as used in Formula D.14, that was used for the calculation of the amount *TEC_{actual}*; and
- (b) for other elements of the calculation—amounts, for the components in the low-efficiency reference set, that are calculated in accordance with clause D.4.2 of Annex D to ISO 23953-2.

Note 1: Section 1 of Schedule 3 to this determination:

- sets out variations to ISO 23953-2 that apply for the purposes of this determination; and
- provides for how ISO 23953-2 applies in relation to low sales volume RSCs.

Note 2: The main formula for calculating the *TEC* is formula D.14 of Annex D to ISO 23953-2, which is set out in clause D.4.2 of that Annex. This formula relies on formulae D.4, D.5, D.6, D.7, D.8 and D.15 of Annex D.

Division 3—Conducting tests

26 Testing requirements—general

For the purposes of this determination, all testing must be conducted in accordance with the relevant test standard.

27 Additional testing requirements—integral, low sales volume RDC that is not oversized and low sales volume RSCs

- (1) This section applies in relation to the following:
- (a) an RDC:
- (i) that is low sales volume; and
- (ii) that is integral; and
- (iii) that is not oversized;
- (b) a low sales volume RSC.

- (2) In addition to the testing that is required to determine the value of TEC_{actual} in accordance with subsection 25(4), the total electrical energy consumption of the cabinet as a whole must be measured directly by testing in accordance with ISO 23953-2.

Note: Section 1 of Schedule 3 to this determination:

- sets out variations to ISO 23953-2 that apply for the purposes of this determination; and
- provides for how ISO 23953-2 applies in relation to low sales volume RSCs.

Part 4—GEMS labelling requirements

28 Purpose of Part

For paragraph 24(1)(b) of the Act, this Part specifies GEMS labelling requirements in accordance with section 26 of the Act for the product classes covered by this determination.

29 Use of star ratings

If, at the time of supply, or offer of supply, of a product covered by this determination, the energy efficiency of the product is described in terms of one or more stars, the number of stars must be calculated in accordance with Schedule 6.

30 Impact of replacement determination

A GEMS labelling requirement of this determination (the *revoked requirement*) is taken to be complied with if:

- (a) this determination is revoked in accordance with paragraph 35(1)(a) of the Act; and
- (b) another GEMS determination (the *replacement determination*) is made in accordance with paragraph 35(1)(b) of the Act; and
- (c) a transitional GEMS labelling requirement (the *replacement requirement*) of the replacement determination provides that, if the replacement requirement is complied with, the revoked requirement is taken to be complied with.

Part 5—Other requirements

31 Purpose of Part

For subsection 24(2) of the Act, this Part specifies other requirements in accordance with section 27 of the Act for product classes covered by this determination.

32 Requirement relating to M-package temperature class

Application of section

- (1) This section does not apply in relation to an RDC that is oversized.

Requirement relating to M-package temperature class

- (2) The table has effect:

	Column 1	Column 2	Column 3	Column 4
Item	The following type of product:	must meet the requirements of one of the following M-package temperature classes:	when tested in accordance with:	at test room climate class:
1	an RDC other than a refrigerated drinks cabinet	M0, M, M1, M2, H1, H2, L1, L2, L3	clause 5.3.3 of ISO 23953-2	3
2	a refrigerated drinks cabinet	M2	clause 5.3.3 of ISO 23953-2	3
3	a normal duty or heavy duty RSC	M1, L1	clause 5.3.4 of EN 16825	4
4	a light duty RSC	M1, L1	clause 5.3.4 of EN 16825	3
5	an ice cream freezer cabinet	C1, C2	Annex F of EN 16901	4
6	a scooping cabinet	G1, G2, G3, L1, L2, L3	clause 6.3.4 of EN 16838	3 or 4

Note 1: Section 1 of Schedule 3 to this determination sets out variations to ISO 23953-2 that apply for the purposes of this determination.

Note 2: Section 2 of Schedule 3 to this determination sets out variations to EN 16825 that apply for the purposes of this determination.

Note 3: Section 3 of Schedule 3 to this determination sets out variations to EN 16901 that apply for the purposes of this determination.

33 Marking plates

- (1) At the time of supply, or offer of supply, of an RSC that is covered by this determination, the RSC must comply with clause 7 of IEC 60335.
- (2) At the time of supply, or offer of supply, of any other product that is covered by this determination, the product must comply with either:

- (a) clause 7 of IEC 60335; or
- (b) whichever of the following is applicable:
 - (i) for an RDC—clause 7.2 of ISO 23953-2;
 - (ii) for an ice cream freezer cabinet—clause 8.2 of EN 16901;
 - (iii) for a scooping cabinet—clause 8.1 of EN 16838.

Note 1: For subparagraph (2)(b)(i), section 1 of Schedule 3 to this determination sets out variations to ISO 23953-2 that apply for the purposes of this determination.

Note 2: For subparagraph (2)(b)(ii), section 3 of Schedule 3 to this determination sets out variations to EN 16901 that apply for the purposes of this determination.

Schedule 1—Product classes

Note: See the definition of *product class* in section 19 of this determination.

1 Product classes

For section 19 of this determination, a numbered *product class* identified in the following table consists of products that:

- (a) are the kind of product indicated; and
- (b) have the characteristics indicated; and
- (c) are not excluded by section 20 of this determination.

Note: The product class is needed in order to identify the relevant values of *M* and *N*, which are used when assessing compliance with the GEMS level requirements set out in Part 3 of this determination.

Kind of product	Product class	Characteristics (code)	Coefficient	
			M	N
Integral, horizontal cabinets:	1	RDC—chiller (IRH)	3.7	3.5
Any of the following:	2	RDC—freezer (IFH)	4.2	9.8
(a) RDCs that are integral and horizontal;	3	RSC—chiller (SRH)	2.555	1790
(b) RSCs that are horizontal;	4	RSC—freezer (SFH)	5.84	2380
(c) ice cream freezer cabinets;	5	Ice cream freezer cabinet (IFH-5)	1	0.009
(d) scooping cabinets	6	Scooping cabinet (GSC or ISC)	10.4	30.4
Integral, vertical cabinets—general:	7	RDC—chiller (IRV)	9.1	9.1
Any of the following:	8	RDC—freezer (IFV)	1.6	19.1
(a) RDCs that are integral and vertical, other than refrigerated drinks cabinets;	9	RSC—chiller (SRV)	1.643	609
(b) RSCs that are vertical	10	RSC—freezer (SFV)	4.928	1472
Integral, vertical cabinets—other:	11	RDC—chiller (IRV-4)	0.69	5.97
Refrigerated drinks cabinets				
Remote, horizontal cabinets:	12	RDC—chiller (RRH)	3.7	3.5
RDCs that are remote and horizontal	13	RDC—freezer (RFH)	4.2	9.8
Remote, vertical cabinets:	14	RDC—chiller (RRV or RRV-2)	9.1	9.1
RDCs that are remote and vertical	15	RDC—freezer (RFV)	1.6	19.1

Schedule 2—Registrations affected by this determination

Note: See section 17 of this determination.

1 Registrations affected by this determination

The following table sets out the models whose registration is affected by this determination.

Brand	Model identifier	Registration number
--------------	-------------------------	----------------------------

Schedule 3—Variations to standards

Note: See the definitions of *ISO 23953-2*, *EN 16825* and *EN 16901* in section 4 of this determination.

1 Variations that relate to ISO 23953-2

(1) For section 4 of this determination, the following table sets out the variations that relate to ISO 23953-2.

Variations that relate to ISO 23953-2		
Item	The following provision:	is taken to be varied by:
1	clause 4.1.1.6	inserting, at the end of the clause: “Some States or Territories might dictate different requirements for dimensions.”
2	clause 4.1.6	inserting, before the Note to the clause: “Remote temperature monitoring is permitted.”
3	paragraph (b) of clause 5.3.2.3.2	omitting “chilled vertical cabinets”, substituting “open cabinets”
4	paragraph (d) of clause 5.3.2.3.2	omitting “frozen”
5	clause 5.3.2.3.2	inserting, after paragraph (d): “(e) The loading height for closed cabinets shall equal half height loading of test packages.”
6	description of Figure 27	omitting “frozen”, substituting “closed”
7	clause 5.3.2.7.1	inserting, after paragraph (b) of the clause: “Automatic lighting function switches are permitted. Should a cabinet have no automatic lighting control function fitted, the lights are to be operated continuously for the duration of the test.”

Variations that relate to ISO 23953-2		
Item	The following provision:	is taken to be varied by:
8	clause 5.3.3.2	<p>omitting the clause, substituting:</p> <p>“5.3.3.2 Closed refrigerated cabinets</p> <p>(a) The test for closed refrigerated cabinets shall always be carried out on the complete cabinet, regardless of the number of doors or lids. Each door or lid shall be opened six times per hour. Doors that are used for service, cleaning or loading of the cabinet only shall not be opened during this test. Where more than one door or lid pertains to the cabinet under test, the sequence in which the doors and lids are opened shall be staggered, i.e. in the case of two doors: door 1 at 0 min, door 2 at 5 min, door 1 at 10 min, door 2 at 15 min, etc. Hinged lids and doors shall be opened beyond an angle of 60°. Sliding glass doors or lids shall be opened beyond 80 % of the maximum area which can be opened. The door or lid shall be opened for a total of 6 s. During this opening period, the doors or lids shall be kept open beyond the minimum required opening for 4 s. Prior to the start of the 12-h period of door opening, each door or lid shall be opened once for 3 min. Where a cabinet is provided with more than one door or lid, each door or lid shall be opened once for 3 min consecutively. Within the test period, the doors or lids shall be opened cyclically for 12 h within 24 h. The 12-h cycle of door or lid opening shall start at the beginning of the test period.</p> <p>(b) If the refrigerated cabinet is fitted with a lighting system, this shall be switched on 1 h before starting the opening cycle. During the test, lighting pertaining to the cabinet shall be lit continuously and anti-sweat heaters shall run for the duration of the test period unless controlled by a time-clock, smart sensor or similar automatic device. Where a cabinet is fitted with an automated lighting control, the tests shall be conducted using the pre-set lighting regime.</p> <p>(c) In all test conditions, maximum energy consumption and minimum efficiency should be determined as worst case.”</p>

(2) For:

- (a) items 5 and 7 of the table to subsection 12(2) of this determination; and
- (b) the following provisions of this determination, to the extent they apply to low sales volume RSCs:
 - (i) subsection 25(4);
 - (ii) subsection 27(2);

ISO 23953-2 applies as if, in addition to the variations of subsection (1), the following apply:

- (c) references to “Commercial Refrigerated Display Cabinets” were to low sales volume RSCs;
- (d) for normal duty or heavy duty RSCs, tests were required to be undertaken at test room climate class 4.

2 Variations that relate to EN 16825

For section 4 of this determination, the following table sets out the variations that relate to EN 16825:

Variations that relate to EN 16825		
Item	The following provision:	is taken to be varied by:
1	clause 4.2.3	omitting the clause
2	clause 5.3.2.4	adding, at the end of the clause: “Alternative test packages as specified in clause 5.3.1.6 of ISO23953-2:2015 are permitted.”
3	clause 5.3.5	omitting the clause
4	clause 6.4.4	omitting the clause

3 Variations that relate to EN 16901

For section 4 of this determination, the following table sets out the variations that relate to EN 16901:

Variations that relate to EN 16901		
Item	The following provision:	is taken to be varied by:
1	Figure 6	replacing cross-section C-C with the following:

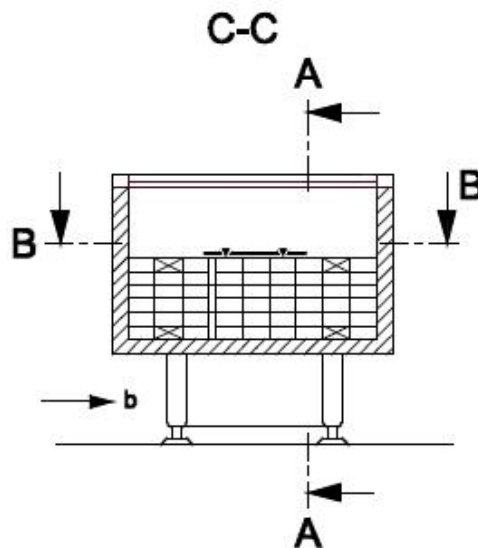

Schedule 4—M-package temperature classes

Note: See the definition of *M-package temperature class* in subsection 10(1) of this determination and the definition of *meets the requirements* of a particular M-package temperature class in subsection 10(2) of this determination.

1 M-package temperature classes—RDCs, RSCs and scooping cabinets

For RDCs, RSCs and scooping cabinets, the M-package temperature classes, and the corresponding requirements, are set out in the following table:

	Column 1	Column 2	Column 3	Column 4
Item	M-package temperature class	Highest temperature, θ_{ah} , of warmest M-package colder than or equal to:	Lowest temperature, θ_b , of coldest M-package warmer than or equal to:	Highest minimum temperature, θ_{al} , of all M-package colder than or equal to:
1	G1	-10	-14	-
2	G2	-10	-16	-
3	G3	-10	-18	-
4	H1	+10	+1	-
5	H2	+10	-1	-
6	L1	-15	-	-18
7	L2	-12	-	-18
8	L3	-12	-	-15
9	M0	+4	-1	-
10	M	+6	-1	-
11	M1	+5	-1	-
12	M2	+7	-1	-

2 M-package temperature classes—ice cream freezer cabinets

For ice cream freezer cabinets, the M-package temperature classes, and the corresponding requirements, are set out in the following table:

	Column 1	Column 2	Column 3
Item	M-package temperature class	Warmest M-package colder or equal to in all tests except lid opening test [°C]	Warmest M-package maximum temperature rise allowed [K]
1	C1	-18.0	2.0
2	C2	-7.0	2.0

Schedule 5—Test room climate classes

Note: See the definition of *test room climate class* in section 5 of this determination.

1 Test room climate classes

For this determination, the following are the *test room climate classes*:

Test room climate class	Dry bulb temperature °Celsius	Relative humidity %	Dew point °Celsius	Water vapour mass in dry air g/kg
3	25	60	16.7	12.0
4	30	55	20.0	14.8
5	40	40	23.9	18.8

Schedule 6—Star ratings

1 Star ratings

For section 29 of this determination, if the energy efficiency index, *EEI*, of the product is within one of the ranges in the following table, the number of stars is as specified in the corresponding row:

Energy efficiency index	Number of stars
$100 \leq \text{EEI} < 130$	1
$77 \leq \text{EEI} < 100$	2
$60 \leq \text{EEI} < 77$	3
$45 \leq \text{EEI} < 60$	4
$35 \leq \text{EEI} < 45$	5
$27 \leq \text{EEI} < 35$	6
$21 \leq \text{EEI} < 27$	7
$16 \leq \text{EEI} < 21$	8
$12 \leq \text{EEI} < 16$	9
$0 \leq \text{EEI} < 12$	10